

### ⚡ Specifications

#### Nominal Voltage(V)

12V

#### Nominal Capacity

10 hour rate	(20A	to	10.80V)	200Ah
5 hour rate	(34A	to	10.20V)	170Ah
1 hour rate	(120A	to	9.60V)	120Ah
1 C	(200A	to	9.60V)	126.7Ah

#### Weight

Approx. 63kg(138.6Lbs.)

#### Internal Resistance (at 1KHz)

Approx. 2.5 mΩ

#### Maximum Discharge Current for

5 seconds: 1600A

#### Charging Methods at 25°C(77°F)

Cycle use:  
 Charging Voltage 14.4 to 15.0V  
 Coefficient -5.0mV/°C/cell  
 Maximum Charging Current : 60A  
 Standby use:  
 Float Charging Voltage 13.5 to 13.8V  
 Coefficient -3.0mV/°C/cell

#### Operating Temperature Range

Charge	-15°C(5°F)	to	40°C(104°F)
Discharge	-15°C(5°F)	to	50°C(122°F)
Storage	-15°C(5°F)	to	40°C(104°F)

#### Charge Retention (shelf life) at 20°C(68°F)

1 month	98%
3 month	94%
6 month	85%

#### Case Material

ABS UL94 HB  
 Option: Flammability resistance of (UL94 V-0)

#### Discharge Time VS. Discharge Current (25°C)

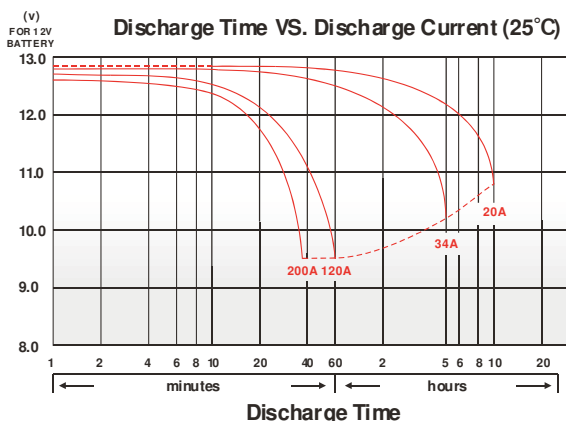

### ⚡ Dimensions

Length (L)	522±3 (20.55±0.12)
Width (W)	238±3 (9.37±0.12)
Height (H)	219±3 (8.62±0.12)
Overall Height (HT)	224±3 (8.82±0.12)

Terminal F18

#### Description of torque value of hard ware for the terminals:

Recommended torque value	M8: 12 N-m (122 kgf-cm)
Maximum allowable torque value	M8: 20 N-m (204 kgf-cm)

mm (inch)

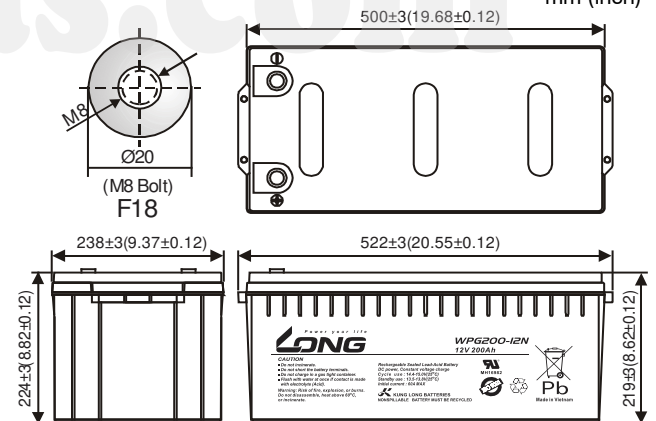

#### Relationship Between Temperature and Charging Voltage

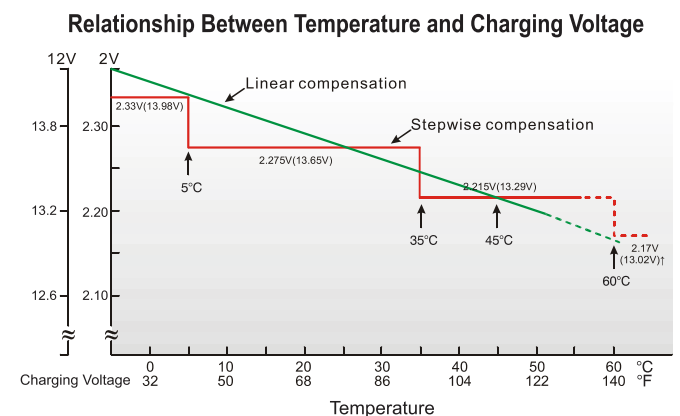

Effect of Temperature on Capacity 25°C (77°F)

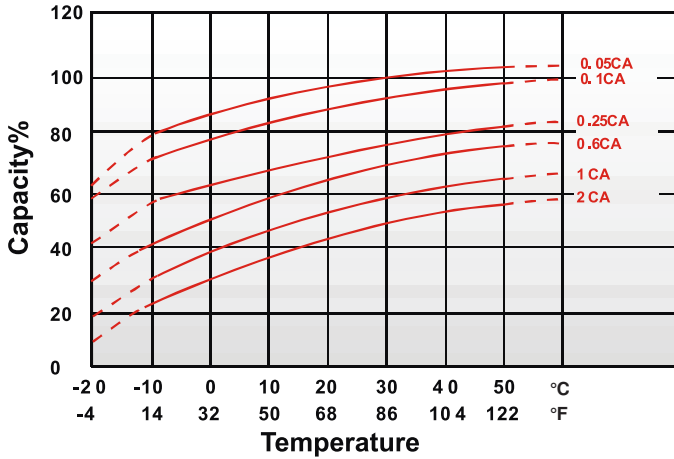

Capacity Retention Characteristic

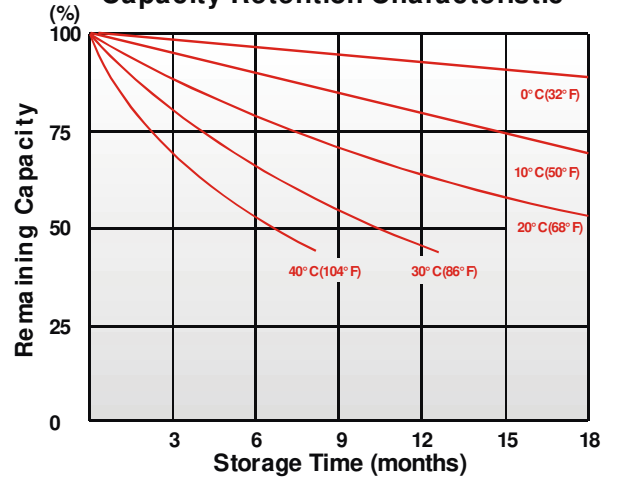

baterias.com

Cycle Service Life

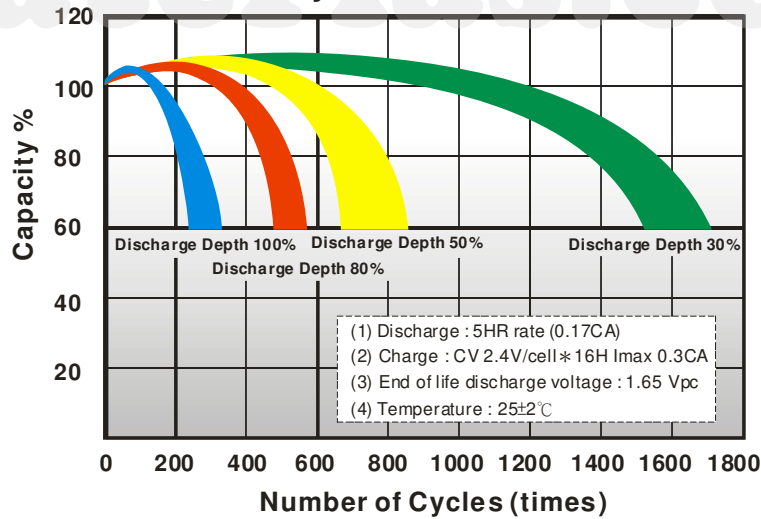

020321-1E