



HC110 SPECIFICATIONS

BATTERY DESIGN

- Absorbent glass mat (AGM) technology
- 12V battery VRLA
- Can be mounted in any orientation except inverted.
- US DOT and IATA certified non-spillable
- Sealed Construction (Non-Spillable Battery)
- Can be fitted with TP brass automotive adaptor on request.
- Shipped fully charged - just install and go!
- Suited for repeated discharges such as running your vehicle with winches or other electrical accessories.

PERFORMANCE FEATURES

- ✧ PHCA: 2200A at 80°F (27°C) for 5 seconds
- ✧ PCCA: 1540A at 0°F (-18°C) for 5 seconds
- ✧ CCA: 1100A at 0°F (-18°C)
- ✧ CA/MCA: 1360A at 32°F (0°C)
- ✧ HCA: 1560A at 80°F (27°C)
- ✧ Reserve capacity: 230 minutes
- ✧ Short circuit current: 5000A
- ✧ Operation temperature range: 5°F (-15°C) to 122°F (50°C)

Nominal Dimensions

Length		Width		Height		Total Height		Weight	
mm	in	mm	in	mm	in	mm	in	kg	pound
330	12.99	173	6.81	214	8.43	237	9.33	34.6	76.1

HIGH RATE DISCHARGE AT 77°F (25°C)

5 sec.	10 sec.	20 sec.	30 sec.
2200A	2000A	1780A	1590A

EXTENDED DISCHARGE AT 77°F (25°C) TO 10.02V

5min	15min	1hr	3hr	5hr	10hr	20hr
414A	208A	69.5A	29A	19.2A	10.9A	5.6A

PHYSICAL CHARACTERISTICS

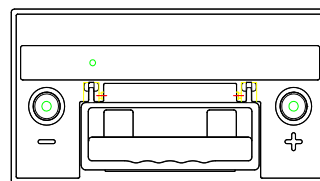
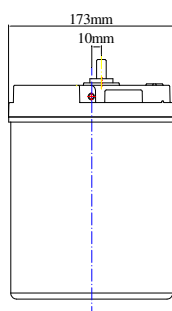
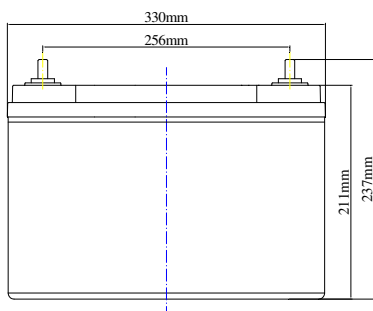

Terminal Type: M10M

