

⚡ Specifications

Nominal Voltage(V)

12V

Nominal Capacity

20 hour rate	(2.5A	to	10.50V)	50Ah
5 hour rate	(8.5A	to	10.20V)	42.5Ah
1 hour rate	(27.5A	to	9.60V)	27.5Ah
1 C	(50A	to	9.60V)	26.67Ah

Weight

Approx. 14.8kg(32.6Lbs.)

Internal Resistance (at 1KHz)

Approx. 6 mΩ

Maximum Discharge Current for

5 seconds:600A

Charging Methods at 25°C(77°F)

Cycle use:	
Charging Voltage	13.8 to 14.4V
Coefficient	-5.0mV/°C/cell
Maximum Charging Current :	15A
Standby use:	
Float Charging Voltage	13.5 to 13.8V
Coefficient	-3.0mV/°C/cell

Operating Temperature Range

Charge	-15°C(5°F)	to	40°C(104°F)
Discharge	-15°C(5°F)	to	50°C(122°F)
Storage	-15°C(5°F)	to	40°C(104°F)

Charge Retention (shelf life) at 20°C(68°F)

1 month	98%
3 month	94%
6 month	85%

Case Material

ABS UL94 HB
Option: Flammability resistance of (UL94 V-0)

Design Life

7-10 Years.

Terminal

F4



⚡ Dimensions

Length (L)

199+3-1 (7.83+0.12-0.04)

Width (W)

166+3-1 (6.54+0.12-0.04)

Height (H)

171+3-1 (6.73+0.12-0.04)

Overall Height (HT)

171+3-1 (6.73+0.12-0.04)

mm(inch)

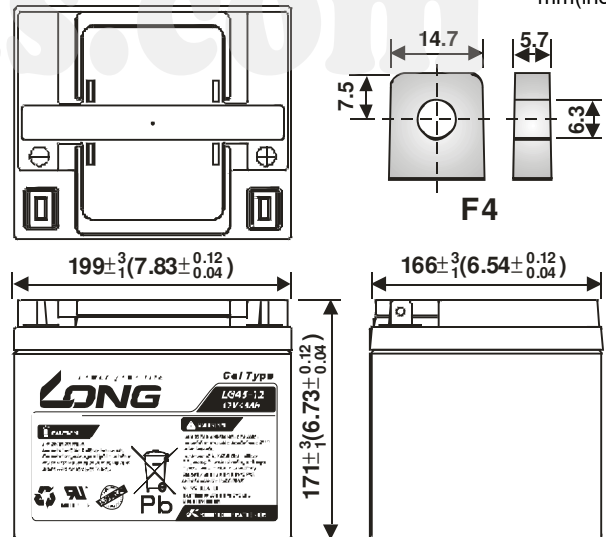

(V) FOR 12V BATTERY Discharge Time VS. Discharge Current (25°C)

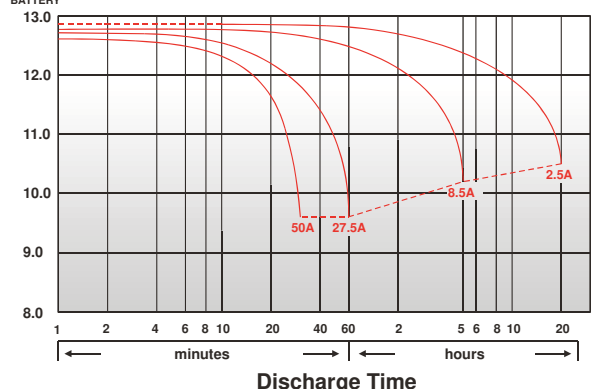

Effect of Temperature on Capacity 25°C (77°F)

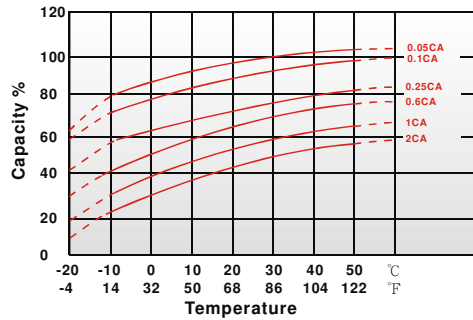

Capacity Retention Characteristic

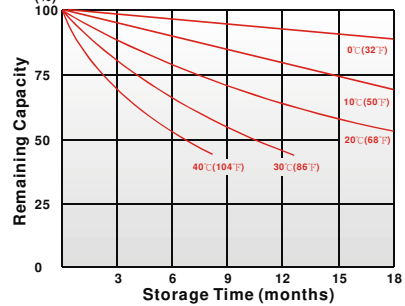

Cycle Service Life

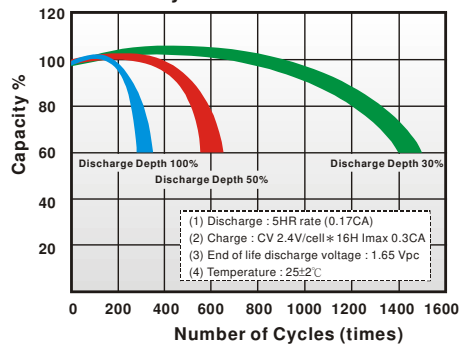

Trickle (or float) Service Life

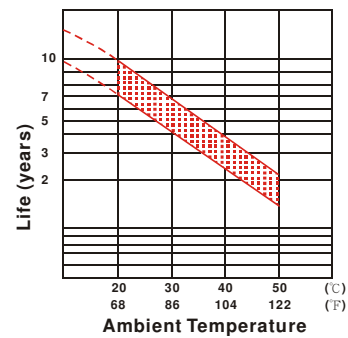

- PERFORMANCE DATA

Discharge Rates in Watts to Various End Voltages at 25°C (77°F)

End Voltage		1.85V	1.80V	1.75V	1.70V	1.67V	1.65V	1.60V
Time								
5	min	216	259	290	311	315	320	325
10	min	154	183	200	210	213	217	221
15	min	114	131	144	150	153	155	157
30	min	70.2	80.9	87.5	90.3	91.4	92.6	93.9
60	min	50.4	53.1	54.7	55.9	56.4	57.0	57.5
120	min	27.7	30.4	31.7	32.8	33.1	33.6	34.0
180	min	20.0	21.8	22.9	23.7	24.0	24.3	24.6
240	min	16.6	17.8	18.4	19.1	19.2	19.6	19.9
300	min	15.6	16.2	16.7	17.0	17.2	17.3	17.5
600	min	8.44	8.92	9.20	9.38	9.42	9.49	9.57
1200	min	4.49	4.77	4.95	5.06	5.10	5.15	5.19

- Discharge Rates in Amperes to Various End Voltages at 25°C (77°F)

End Voltage		1.85V	1.80V	1.75V	1.70V	1.67V	1.65V	1.60V
Time								
5	min	125	149	167	179	185	189	193
10	min	78.1	93.5	103	110	113	116	118
15	min	71.6	77.7	80.6	83.0	83.6	84.5	85.5
30	min	40.9	45.6	47.5	49.0	49.4	50.0	50.6
60	min	24.4	27.1	28.1	28.8	29.0	29.2	29.5
120	min	14.3	15.4	16.0	16.4	16.6	16.8	17.0
180	min	10.6	11.2	11.6	11.9	12.0	12.1	12.2
240	min	8.67	9.16	9.41	9.59	9.66	9.80	9.88
300	min	7.69	8.09	8.33	8.50	8.56	8.62	8.69
600	min	4.40	4.64	4.75	4.81	4.83	4.86	4.90
1200	min	2.32	2.44	2.50	2.55	2.57	2.59	2.61

All data on the spec. sheet is an average value:

The tolerance range : $X < 6\text{min}$ (+15%~-15%), $6\text{min} \leq X < 10\text{min}$ (+12%~-12%), $10\text{min} \leq X < 60\text{min}$ (+8%~-8%), $X \geq 60\text{min}$ (+5%~-5%)

160120-1M