

⚡ Specifications

Nominal Voltage(V)

12V

Nominal Capacity

20 hour rate	(1.65A	to	10.50V)	33Ah
10 hour rate	(3.135A	to	10.50V)	31.35Ah
5 hour rate	(5.61A	to	10.20V)	28.05Ah
1 C	(33A	to	9.60V)	18.7Ah
3 C	(99A	to	9.60V)	13.2Ah

Weight

Approx. 10.1kg(22.2Lbs.)

Internal Resistance (at 1KHz)

Approx. 6.5 mΩ

Maximum Discharge Current for

5 seconds: 495A

Charging Methods at 25°C(77°F)

Cycle use:	
Charging Voltage	14.4 to 15.0V
Coefficient	-5.0mV/°C/cell
Maximum Charging Current :	9.9A
Standby use:	
Float Charging Voltage	13.5 to 13.8V
Coefficient	-3.0mV/°C/cell

Operating Temperature Range

Charge	-15°C(5°F)	to	40°C(104°F)
Discharge	-15°C(5°F)	to	50°C(122°F)
Storage	-15°C(5°F)	to	40°C(104°F)

Charge Retention (shelf life) at 20°C(68°F)

1 month	92%
3 month	90%
6 month	80%

Case Material

ABS UL94 HB
Option: Flammability resistance of (UL94 V-0)

Design Life

3-5 Years.

Terminal

F4



⚡ Dimensions

Length (L)	197±2-1 (7.76±0.08-0.04)
Width (W)	131±2-1 (5.16±0.08-0.04)
Height (H)	159±2-1 (6.26±0.08-0.04)
Overall Height (HT)	180±2-1 (7.09±0.08-0.04)

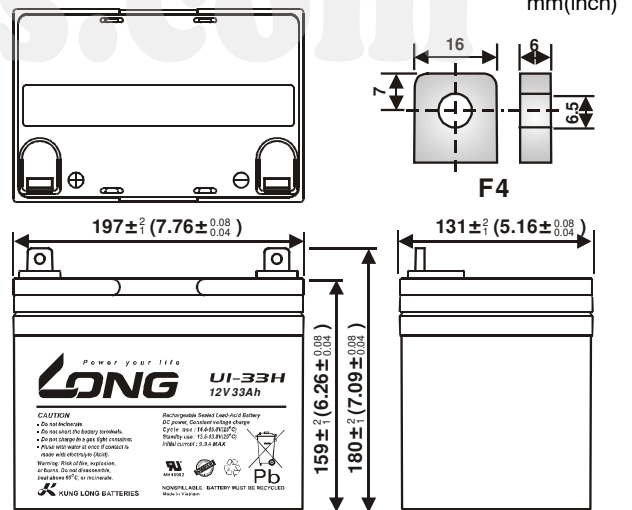

(V) FOR 12V BATTERY Discharge Time VS. Discharge Current (25°C)

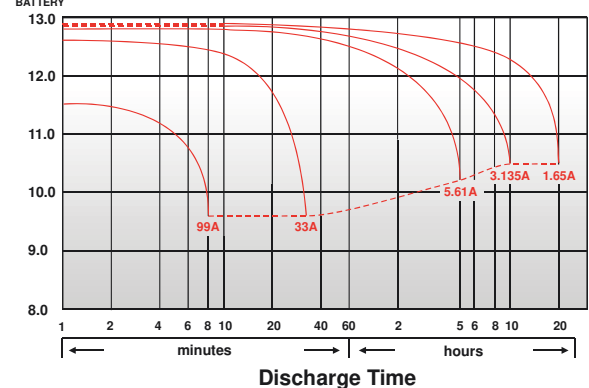

Effect of Temperature on Capacity 25°C (77°F)

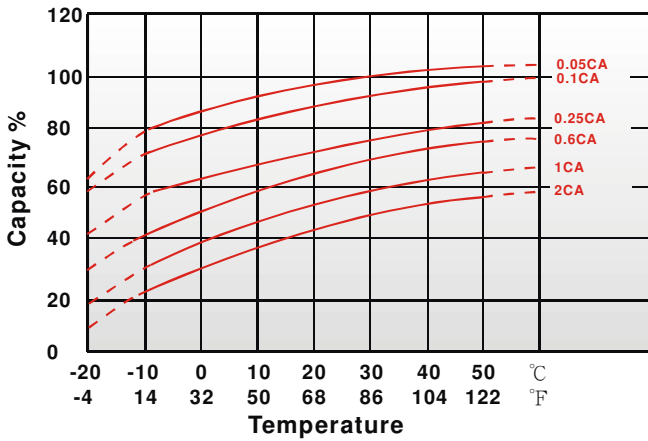

Capacity Retention Characteristic

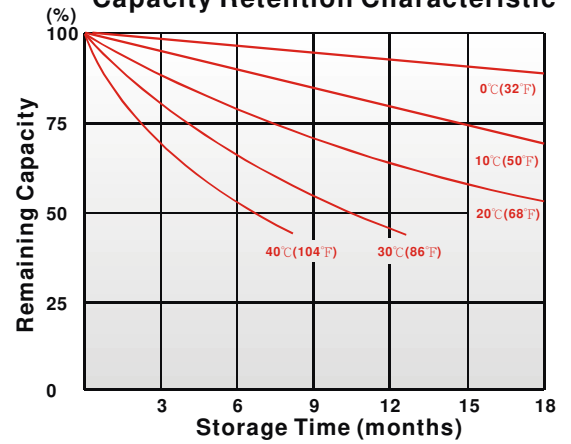

baterias.com

Cycle Service Life

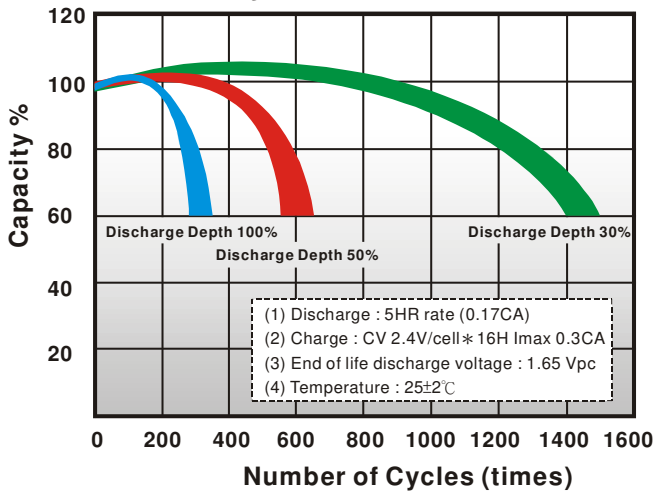

Trickle (or float) Service Life

